

MODEL#S745-SW

Rev: 0

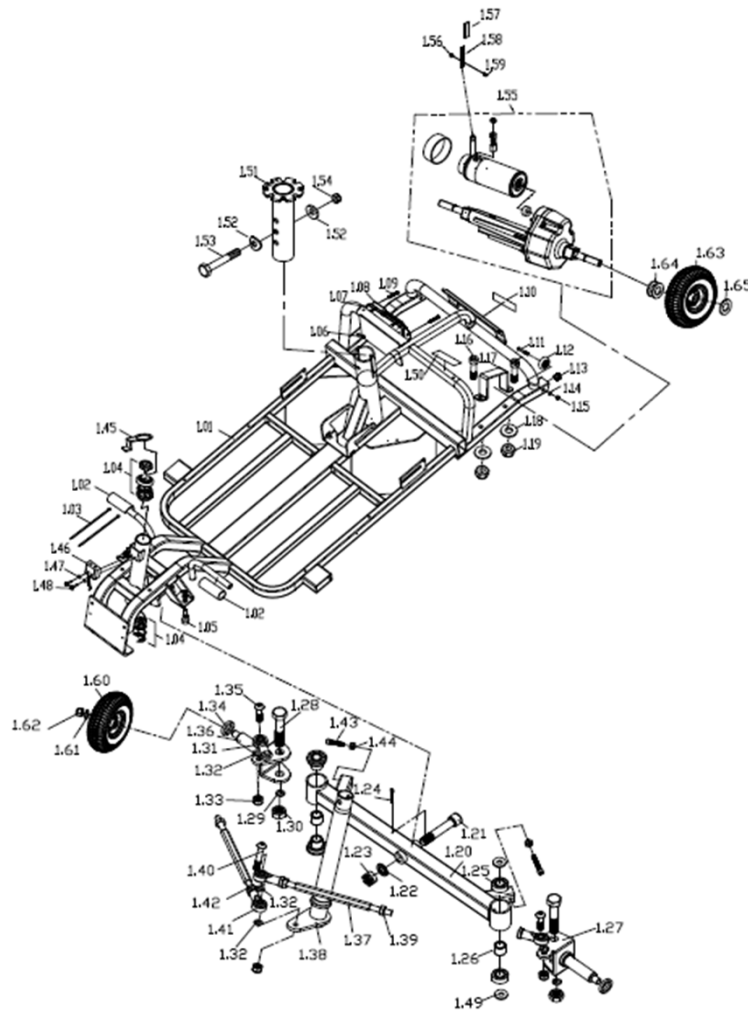

REF#	PART NO.	DESCRIPTION	REF#	PART NO.	DESCRIPTION	REF#	PART NO.	DESCRIPTION
1	30303M19	FRAME ASSY	23	53212002	CASTLE NUT, M12	45		
2	43700285	VELCRO TAPE FEMALE, 2", 1 ROLL	24	54100002	COTTER PIN, ϕ 1/8" x 22L	46		
3	72700003	TIE, TSL-120-M-MT, BLACK	25	53400067	BEARING	47		
4	53400024	BEARING SET,FORK 8 PCS/SET	26	41380209	SPACER	48		
5	44600150	BUFFER, RUBBER BLOCK, M10x30L	27	30303186	AXLE ASSY OF FRONT WHEEL L	49	53100004	WASHER, ϕ 13x ϕ 24x2.0T
6	53204002	NYLON NUT, BZ, M4*P0.7	28	51054M02	SCREW	50	43700285	VELCRO TAPE FEMALE, 2", 1 ROLL
7	64520010	CONTROLLER	29	53158002	SPRING WASHER, ϕ 1/2" X 3.5t	51	32101023	UPPER SEAT POST ASSY P321
8	61230139	CAP	30	53278011	NYLON NUT, 1/2-20UNF	52	53110001	CONCAVE WASHER, M10
9	50104013	SCREW, M4x30L	31	41300088	BALL JOINT, ϕ LEFT SIDE	53	51010003	HEX HEAD BOLT, M10 X 60L
10	43700285	VELCRO TAPE FEMALE, 2", 1 ROLL	32	53108053	WASHER	54	53210003	NYLON NUT, M10*P1.5
11	50408002	SCREW, M8 x 58L	33	53208012	NUT, NYLON, M8xP1.25, BZ	55	62009057	TRANSAXLE ASSY
12	43620030	ANTI-TIPPER WHEEL, W/BEARING 608Z, $\frac{5}{60}$ *18W	34	42300009	SPACER, ϕ 24x17.2x4.2t	56	53205007	NYLON NUT,M5, BZ
13	4360BM56	BLACK PLUG	35	51208009	SCREW, M8x30L	57	43701298	RELEASE HANDLE SLEEVE
14	53108008	WASHER, ϕ 16x ϕ 8.2x1.0t,BZ	36	30303187	AXLE ASSY OF FRONT WHEEL R	58	41200704	EXTENSION OF RELEASE HANDLE
15	53208004	NYLON CAP-NUT,M8	37	41300415	CONNECTING ROD, LONG	59	51205009	ALLEN SCREW, M5*12L
16	51108051	BOLT, M8*40L	38	30303M20	TUBE ASSY OF STEERING AXLE	60	33100669	FRONT WHEEL ASSY
17	41200494	BRACKET FOR METEOR M4 TRANSAXLE	39	53208013	NUT, M8, LH THREAD	61	53110005	WHAHER, ANTI-SLI ϕ 21 x ϕ 10.2 x 3.0t
18	53108009	WASHER, M8x1.6t (ϕ 18)	40	51208020	SCREW, M8*45L, BLK	62	53210003	NYLON NUT, M10*P1.5
19	53208012	NUT, NYLON, M8xP1.25, BZ	41	41300606	BALL JOINT, ϕ RIGHT SIDE	63	32600452	DRIVE WHEEL ASSY.
20	30303M21	FRONT BEARING ARM ASSY	42	53208014	NUT, M8	64	53116M02	WASHERS ϕ 28* ϕ 17*1t
21	51112005	PIVOT BOLT, M12 x 65L	43	51106008	CAPSCREW, ALLEN HEAD, M6 x 30L	65	53100004	WASHER, ϕ 13x ϕ 24x2.0T
22	53112005	SPRING WAHSER, M12	44	53206014	NUT(NO NYLON CAP), M6*1 (BLACK)	66		

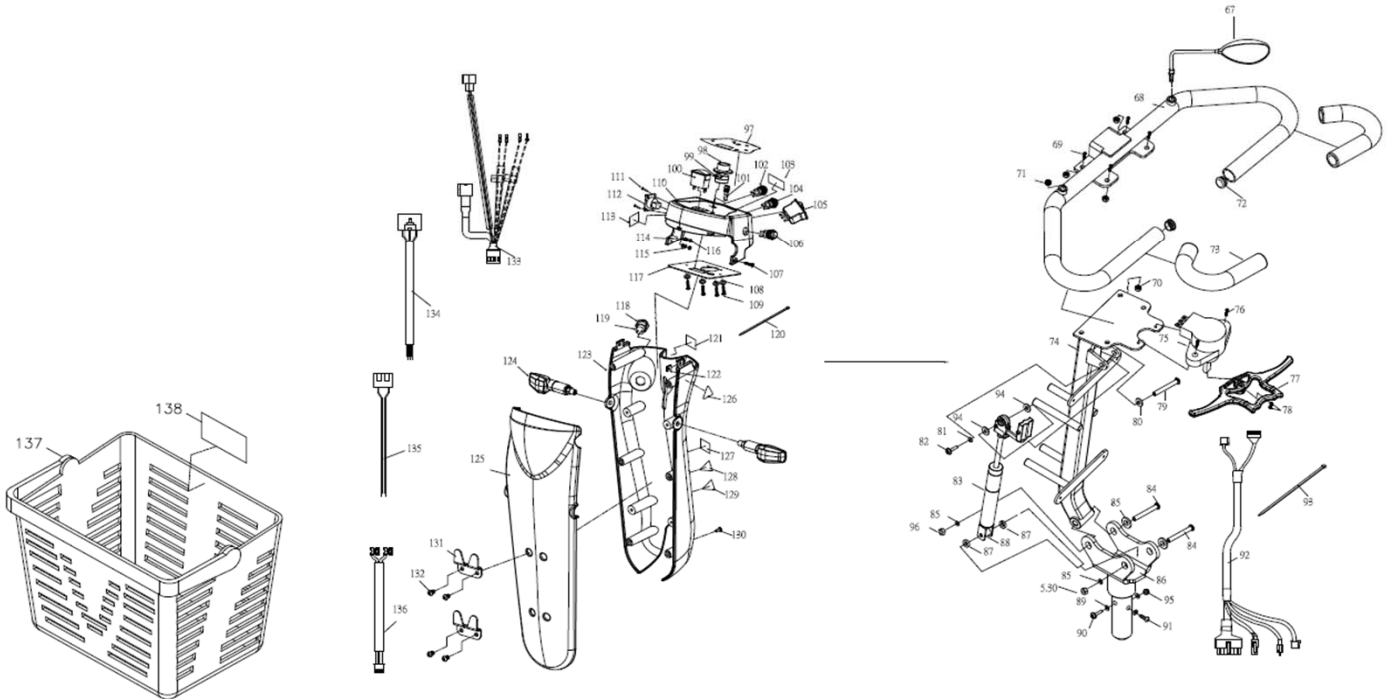

REF#	PART NO.	DESCRIPTION	REF#	PART NO.	DESCRIPTION	REF#	PART NO.	DESCRIPTION
67	467000064 6700010	BACK MIRROR, LH/RH	91	51206M36	SCREW, M6x10L	115	53102001	SPRING WASHER, M2
68	33503152	TILLER HANDLE ASS'Y	92	631M0005	LINKING WIRE OF TILLER	116	53202001	NUT, M2
69	51206017	ALLEN P-HEAD SCREW, M6 x 16L	93	72700003	TIE, TSL-120-M-MT, BLACK	117	61100027	PCB MODULAR,DASHED BOARD
70	53206010	NYLON NUT, BLACK, M6	94	53108019	WASHER, M8*2.2t(§ 18), BLACK	118	63700036	KEY SWITCH W/CONNECTING WIRE, S830
71	50708006	SET SCREW, M8x10L	95	53206010	NYLON NUT, BLACK, M6	119	33700217	Key set
72	43600037	7/8" PLUG, BLACK	96	53208012	NUT, NYLON, M8xP1.25, BZ	120	72700003	TIE, TSL-120-M-MT, BLACK
73	45700102	FOAMING TUBE	97	75142M35	LABEL	121	75145219	POWER OFF CAUTION LABLE
74	33503M11	TILLER ASS'Y	98	61188009	KNOB	122	54600001	NUT SHEET
75	61010047	VARIABLE RESIDTENCE	99	61020006	POTENTIMETER, VR30K, COSMOS RV24	123	26051M09	REAR OF INSTRUMENT
76	50604004	SCREW, M4x10L	100	61220006	METER, SD-563 DC18V-21. 5V-26V	124	61200158	LED DIRECTION LIGHT
77	43601255	STIR BAR ASS'Y	101	61200072	POWER INDICATOR	125	30529M12 30510M25	FRONT COVER OF INSTRUMENT
78	50704003	SCREW, PPH, M4*8L	102	33700215	HORN SET	126	75142005	LABEL,WARNING.
79	50408904	SCREW, M6x16L, FEMALE	103	75142M36	LABEL	127	75145218	READING LABLE
80	53108019	WASHER, M8*2.2t(§ 18), BLACK	104	33700216	HEAD LIGHT SET	128	75143207	STICKER, TILLER ADJUST 40*49,5L
81	53106011	WASHER, φ13xφ6.5x1.0t	105	33700228	SWITCH, TURN SIGNAL	129	75145219	POWER OFF CAUTION LABLE
82	50406903	SCREW AND NUT,M6*14L	106	33700211	HAZARD LIGHT SET	130	50604004	SCREW, M4x10L
83	41300366	ELEVATING CYLINDER	107	51904001	SCREW, M4*12(BLACK)	131	41200199	BASKET BRACKET 2.5t
84	51208M15	SCREW M8x52	108	53104003	WASHER, M4	132	51206005	SCREW, M6*10L
85	53108008	WASHER, φ16xφ8.2x1.0t,BZ	109	51904M01	SCREW M4*20L	133	634M0002	LINKING WIRE OF LIGHTS
86	33503M10	FIXING ASS'Y OF TILLER	110	26051M07	UPPER COVER OF INSTRUMENT	134	63500009	CONNECTING WIRE, POT
87	53108017	WASHER, M8 x 4t(φ22)	111	50202001	SCREW, M2 x 12L	135	63500018	CONNECTING WIRE, SPEED POT
88	53680001	SPACER (ED)φ15*φ8*17.5L	112	33700279	PLUG	136	63542001	POWER CORD.
89	53106002	WASHER, BLACK, φ13xφ6.5x1.1t	113	75141414	LABEL	137	43780088	BASKET
90	51206015	SCREW, M6x35L	114	53103002	WASHER, M3*φ8*1t	138	75143204	BASKET LOAD STICKER

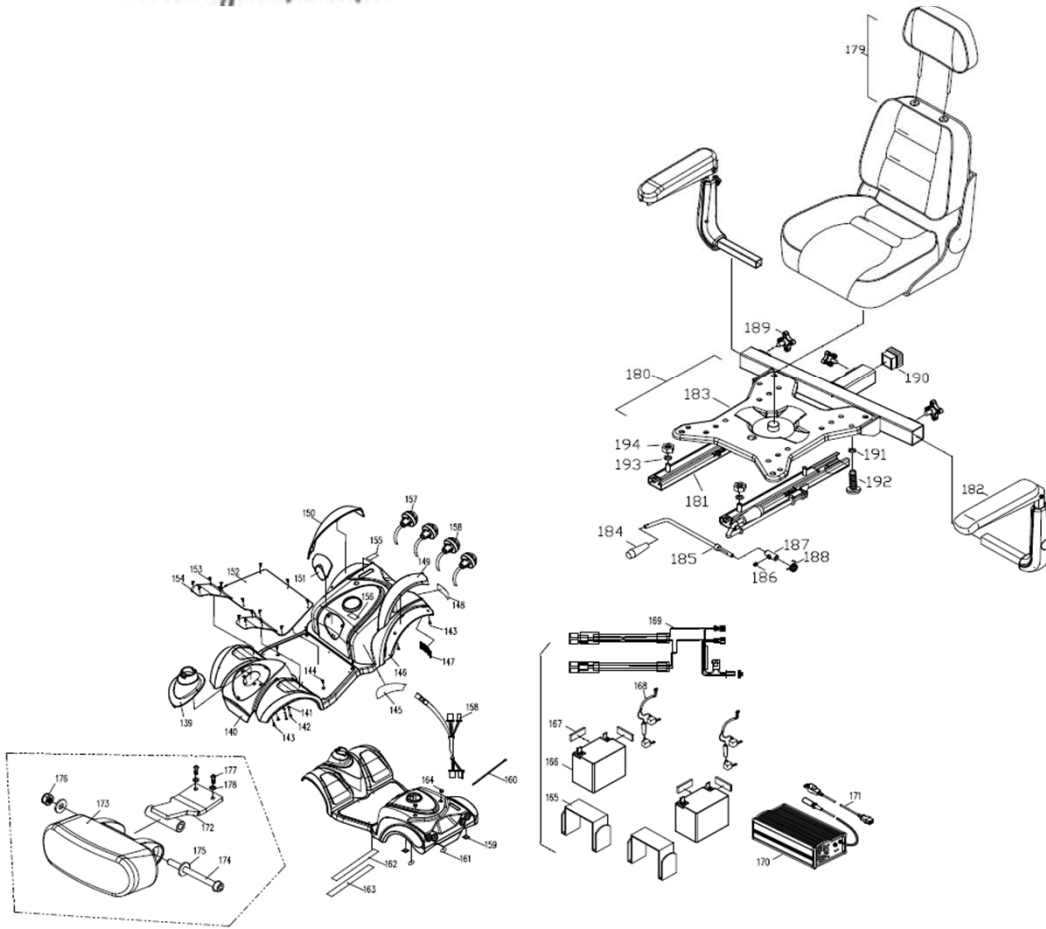

REF#	PART NO.	DESCRIPTION	REF#	PART NO.	DESCRIPTION	REF#	PART NO.	DESCRIPTION
139	30529M08 30510M21	FRONT DECORATE COVER	158	634M0001	LINKING WIRE OF REAR LIGHT	177	50604004	SCREW, M4x10L
140	26051M01	FRONT COVER	159	61210034	CLIP, SELF-MOUNT	178	53104003	WASHER, M4
141	53104003	WASHER, M4	160	72700003	TIE, TSL-120-M-MT, BLACK	179	32200321	SEAT ASS'Y
142	50104050	SCREW, PPH, M4*35MM, BK	161	43701225	VELCRO TAPE MALE, 16MM, 1 ROLL	180	32228015	CAPTAIN SEAT ONLY, WITH/ RECLINE & MC7/MC22 COLOR
143	50604004	SCREW, M4x10L	162	43701225	VELCRO TAPE MALE, 16MM, 1 ROLL	181	41700077	SLIDE MECH. ASS'Y., WITH RELEASE LEVER
144	51904M01	SCREW M4*20L	163	43701224	VELCRO TAPE FEMALE, 16MM, 1 ROLL	182	31000089 31000090	ARMREST ASS'Y, LH/RH
145	75100173	DECAL, With you for lift , LARGE	164	43600039	25 DIA END PLUG, φ1"*0.9t	183	32103M01	SEAT BASE ASS'Y
146	26051M02	REAR COVER	165	43701080	REUSEABLE FASTENER, 2"* 660MML, BLACK	184	43600M38	TIP FOR LEGREST ADJUST.
147	43700284	VELCRO TAPE, 2" , MALE, 1 ROLL	166	6610M008	BATTERY	185	24210002	RELEASE LEVER, "L" TYPE
148	75142201	DECAL, MERITS	167	4360JM94	BATTERY WASHER	186	50708006	SET SCREW, M8x10L
149	30510M23 30510M24	DECORATE COVER OF REAR WHEEL L/R	168	63200012	CONNECTING WIRE,BATTERY (INCLUDING 40A FUES)	187	41500007	LOCATING,R.LEVER
150	30529M09 30510M22	REAR DECORATE COVER	169	633M0007	POWER WIRE OF CONTROLLOR	188	53500029	TORQUE SPRING,LEVER
151	4460AM67	FOOTMAT	170	6510M008	CHARGER	189	43600270	KNOB, M10 x 13L
152	54600036	NYLON SCREW (F4410)	171	63600035	AC CORD FOR AUSTRALIA	190	4360EM10	PLUG
153	4460AM68	FRONT MAT	172	4120DM26	BRACKET ASS'Y OF HEADLIGHT	191	53108008	WASHER, φ16xφ8.2x1.0t,BZ
154	75143208	DECAL, FREE-WHEELING	173	61200157	LIGHTS ASS'Y	192	50408003	SCREW, M8*20L
155	75130707	DECAL, "MAX. WEIGHT CAPACITY" (300LB/135KG)	174	50104M05	PHILIPS SCREW M4*45L	193	53108013	SPRING WASHER, M8 x 2.5t
156	61200214	LED DIRECTION LIGHT	175	53104003	WASHER, M4	194	53208010	NYLON NUT, M8
157	61200213	LED REAR LIGHT	176	53204002	NYLON NUT, BZ, M4*P0.7	195		